

The Playing Card Cube aka the Business Card Cube

The Playing Card Cube is a traditional design from the Western European tradition that dates back to at least 1800. There is a page setting out the early evidence for the existence of this design in the History section of this site.

The design was originally made from playing cards but it can also be made from business or cardboard tickets or from any other suitably sized pieces of light card. The difference in dimensions of the cards used will alter the size of the flaps but not the overall shape and structure of the cube. You will need six cards for each cube.

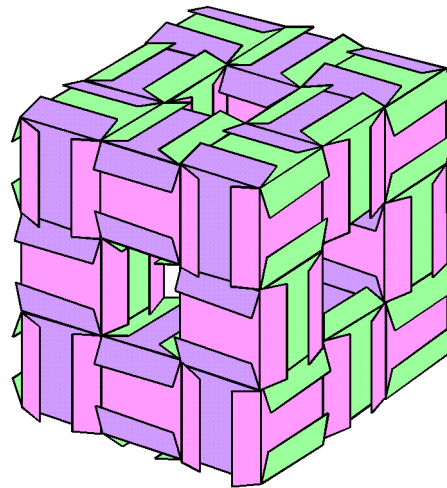

Playing Card Cubes can be linked together by interweaving their external flaps, and so can be used to create towers, buildings etc. The earliest evidence we have for the existence of this design shows that this property of the design was already known at that time.

Sometime during the late 1980s or early 1990s the American paperfolder Jeannine Mosely linked cubes made from business cards together to build a depth three Menger Sponge. A picture of a depth one sponge is shown above. Jeannine also discovered that it was possible to clad the exterior of the cubes, or, at least those parts of the exterior that were exposed, using other cards folded in the same way, and thus improve the aesthetics of the design.

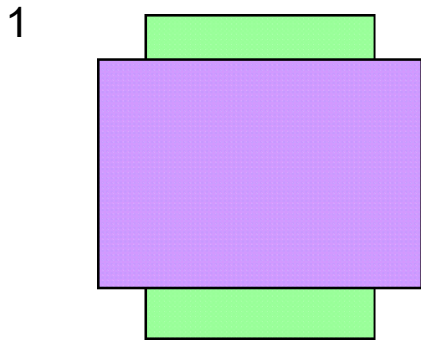

1. Arrange two cards like this so that the surfaces you want to show on the outside of the cube are touching each other face to face. Try to make sure that the cards are centred as evenly as possible.

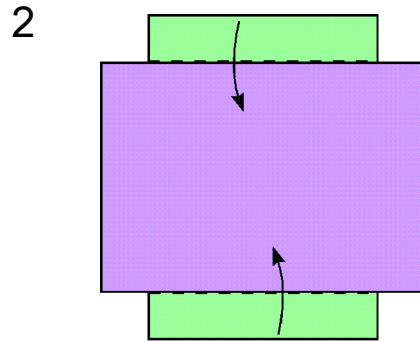

2. Fold the ends of the rear card tightly around the edges of the front card and crease firmly.

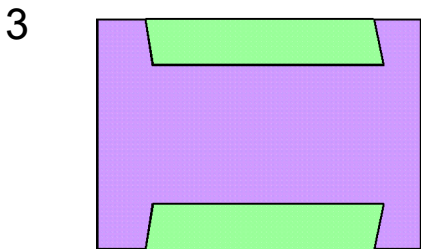

3. This is the result. Turn over sideways.

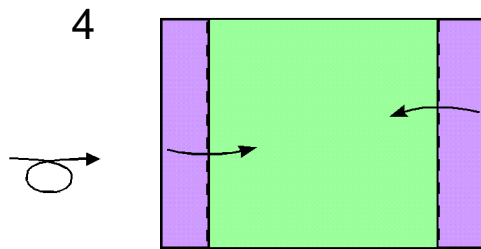

4. Fold the ends of the rear card tightly around the edges of the front card and crease firmly.

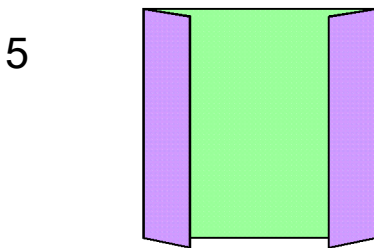

5. The cards should now be firmly locked together. Take them apart taking care to open out the folds as little as possible. (In the assembly diagrams many of the flaps have been shown in a slightly splayed position. This is to help make the pictures clear. You will get a better looking cube if you keep enough spring in the folds to hold the flaps tight against the faces of the cube.)

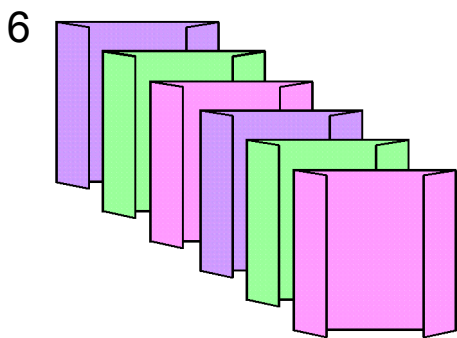

6. Repeat steps 1 through 5 on the other two pairs of cards.

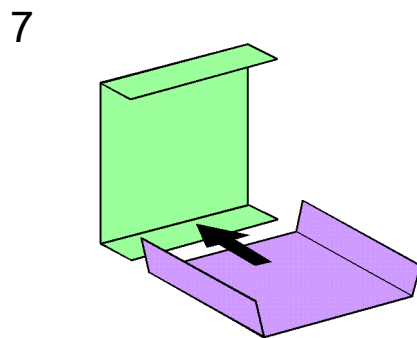

7. The first two cards slide together like this.

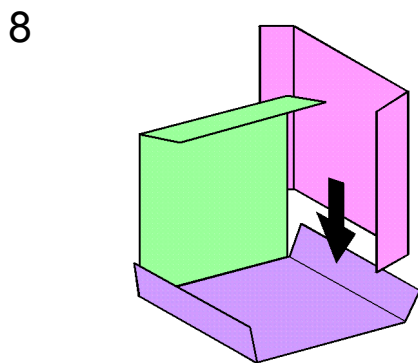

8. Add the third card of the third colour.

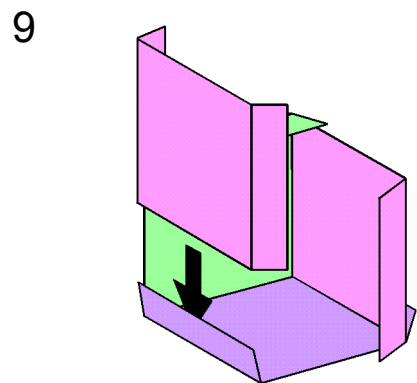

9. The fourth card goes in like this.

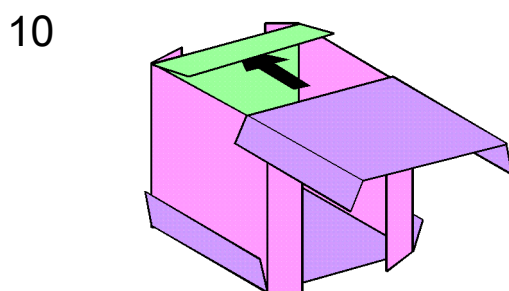

10. And the fifth like this.

11

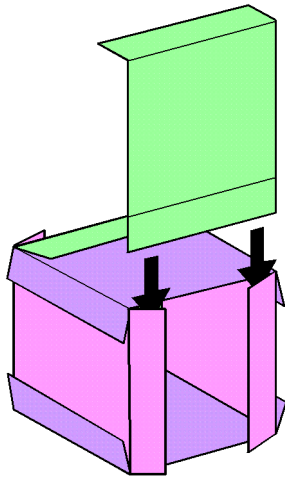

11. Slide the sixth card into place to complete the cube.

12

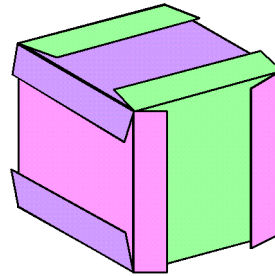

12. The Playing Card Cube is finished

Building Playing Card Cubes into lattices

Pictures 13 through 16 show you how to build a second cube on top of the first. If you have enough cards and enough patience you can continue this process to create large lattices of integrated Business Card Cubes in this way.

13

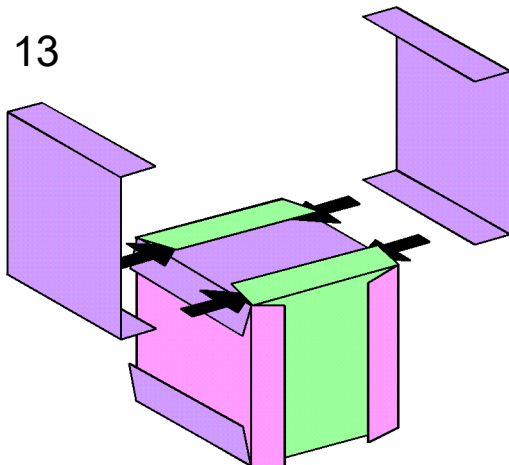

13. Add two more cards underneath the flaps of the existing cube.

14

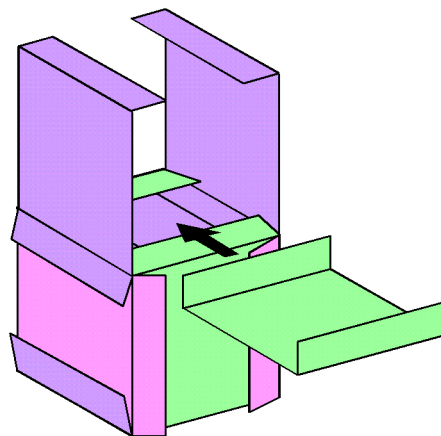

14. Slide the third card into position.

15

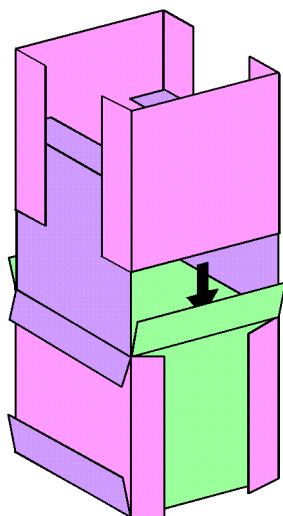

15. Add two more cards like this.

16

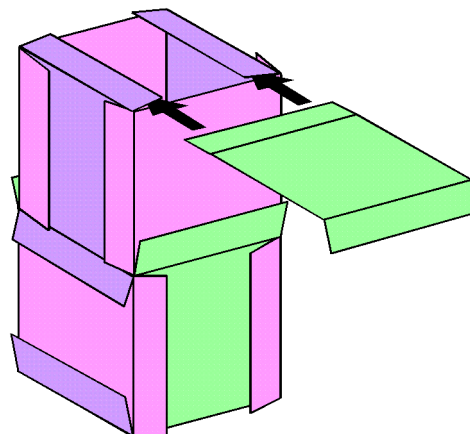

16. Slide the last card into place to complete the second cube.

17

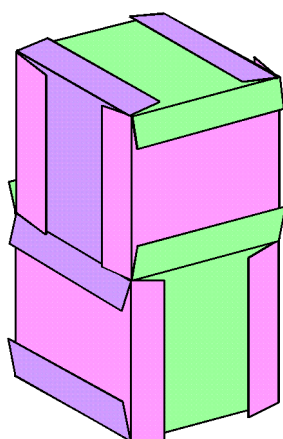

17. Two cubes have been joined together. Further cubes can be added to any face in a similar way

18

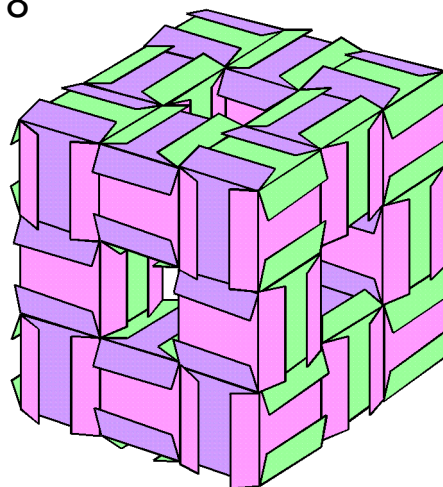

18. This lattice is a depth 1 Menger Sponge. The only limit to the size of the structures you can create is the number of suitable cards you have available and your supply of patience.

