

Lovebird

Designed by David Mitchell

Lovebird is a double image see-through design of a hovering bird which, when held up to the light, reveals a heart in the centre. It is a creative response to the earlier design called Lighthearted by Wayne Brown.

Lovebird was designed in 2000.

You will need a single square of irogami in a suitable colour.

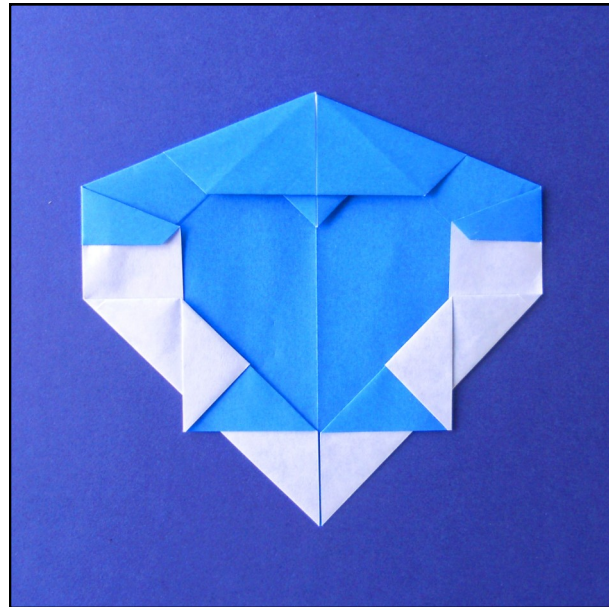

Begin with your paper arranged white side up.



1. Make a crease across the paper one third of the way down from the top.

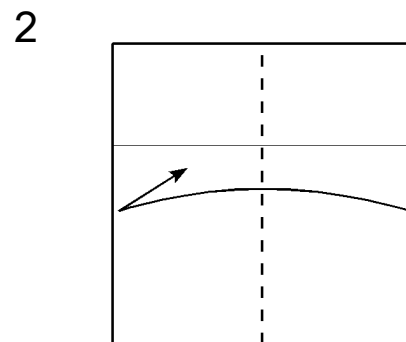

2. Fold in half sideways, then unfold.

3

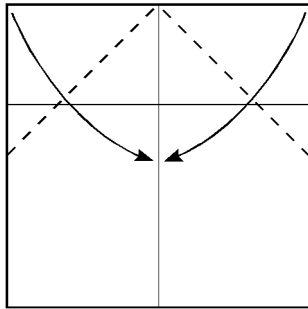

3. Fold both the top corners inwards so that both halves of the top edge lie on the upright centre crease.

4

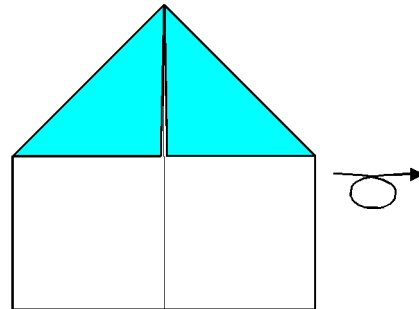

4. Turn over sideways.

5

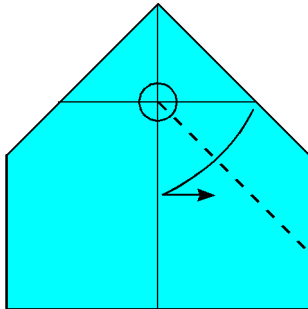

5. Make a diagonal crease in the right hand half of the paper by folding the horizontal crease onto the vertical one.

6

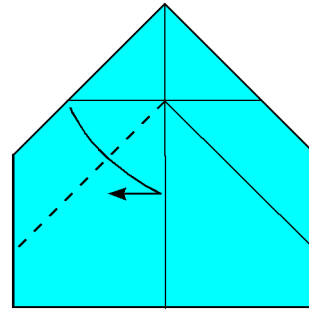

6. Make a similar crease in the left hand half of the paper.

7

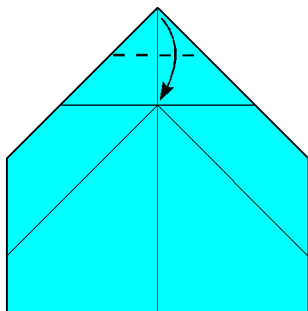

7. Fold the top point downwards onto the point where the other creases intersect.

8

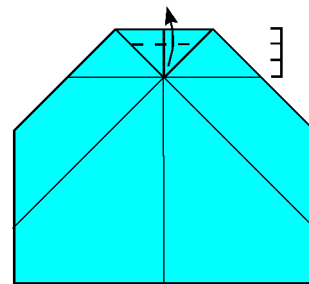

8. Fold approximately two thirds of the front flap upwards again.

9

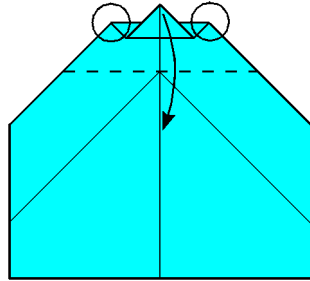

9. Fold the top section of the paper downwards using the crease made in step 1.

10

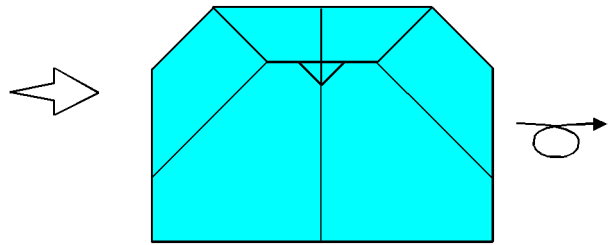

10. The corners marked with circles in picture 9 should now touch the diagonal creases. Turn over sideways.

11

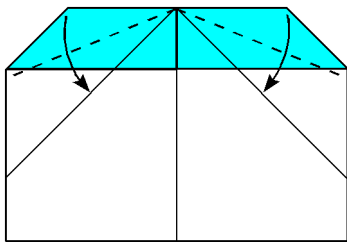

11. Fold each half of the top edge downwards onto the corresponding diagonal crease.

12

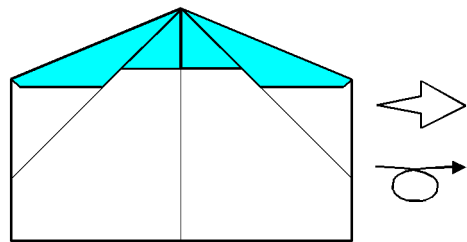

12. Turn over sideways.

13

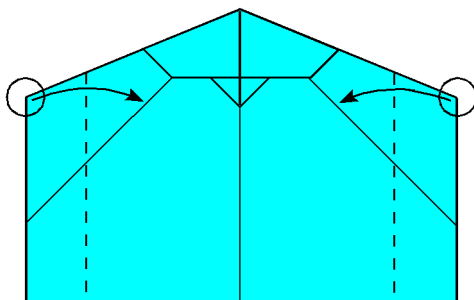

13. Fold both outside edges inwards. Make sure the corners marked with circles end up lying on top of the diagonal creases.

14

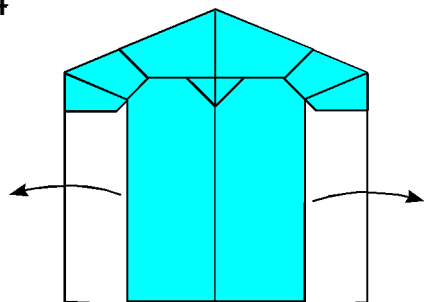

14. Open out the folds made in step 13.

15

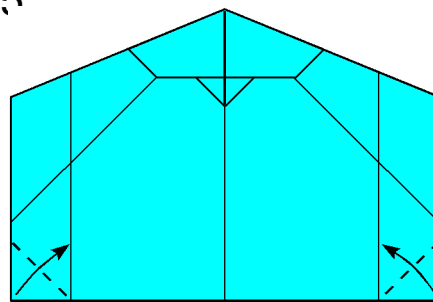

15. Fold both bottom corners inwards using the folds made in step 13 as guides.

16

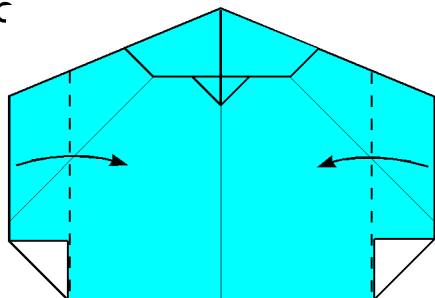

16. Remake the folds made in step 13.

17

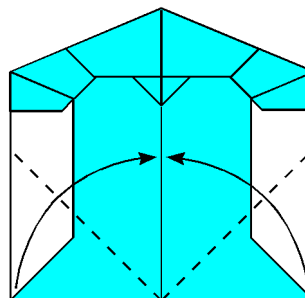

17. Fold both bottom corners inwards.

18

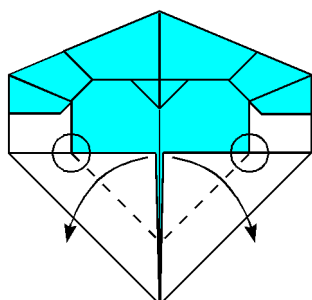

18. Now fold the bottom corners outwards again, taking care to locate the folds in relation to the points marked with circles.

19

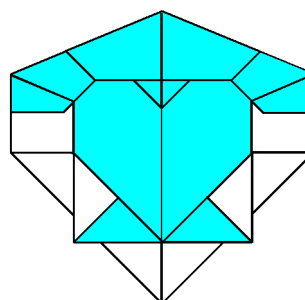

19. Lovebird is finished. When viewed normally only the hovering bird is visible.

20

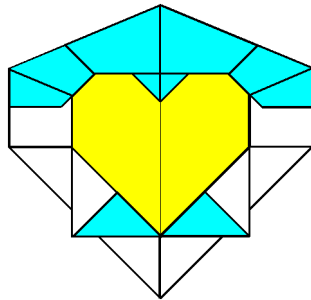

20. To see the heart hold Lovebird in front of a window or lamp.

Copyright David Mitchell 2018
www.origamiheaven.com