

Mouse

Designed by David Mitchell

I created this rather friendly little mouse in 2006 when I was commissioned to write and illustrate a book of easy animal and bird designs.

Mouse is a pretty standard origami design apart from the unusual way the layers of the head and ears can be re-arranged to lock them together.

You will need a square of grey or brown paper. If you use homogeneous paper your Mouse will be all one colour. If you use irogami it will have a white face.

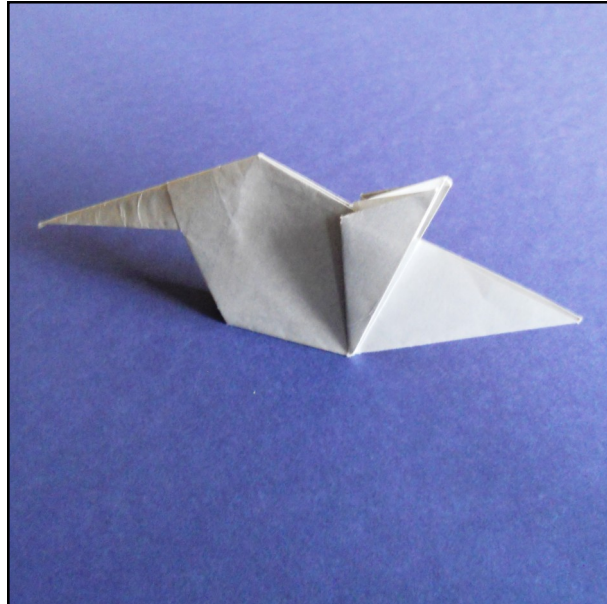

If you are using irogami begin folding with your paper arranged white side up.

1

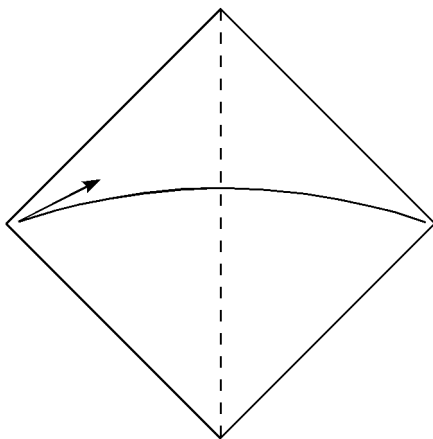

1. Fold in half sideways, then unfold.

2

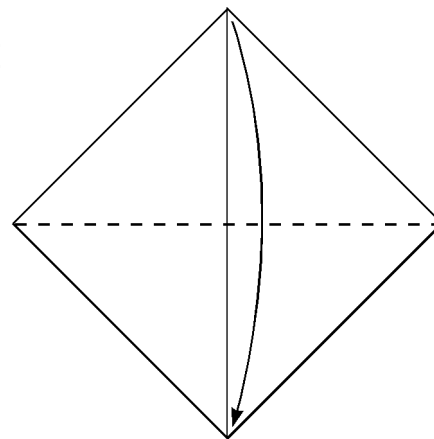

2. Fold in half downwards.

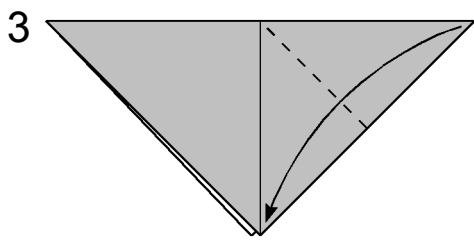

3. Fold the right hand corner down to lie on top of the bottom corner.

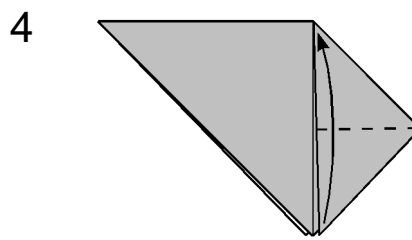

4, Fold the triangular flap in half upwards.

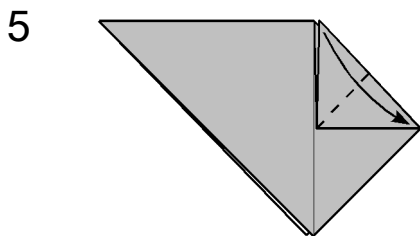

5. Fold this new triangular flap in half as well.

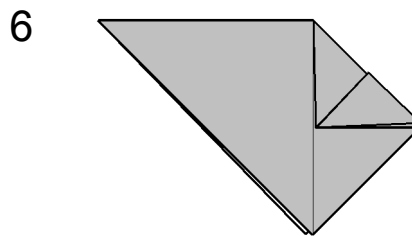

6. Make sure all the creases made in steps 3 through 5 are really sharp, then unfold completely, making sure you don't turn the paper over as you do so.

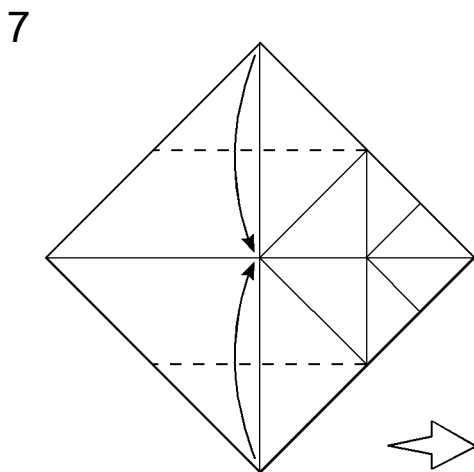

7. Fold the top and bottom corners into the centre of the design. the next picture has been drawn to a larger scale.

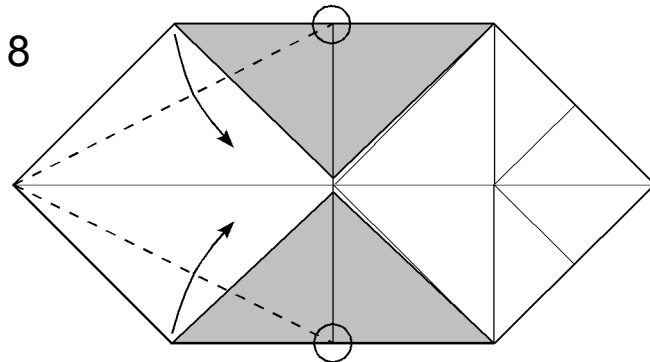

8. Begin to form the tail by making these two folds. Note that the creases should run from the tip of the right hand point of the design to the intersections of the vertical crease made in step 1 with the edges of the paper (marked with circles). It is very important to make these folds as accurately as possible.

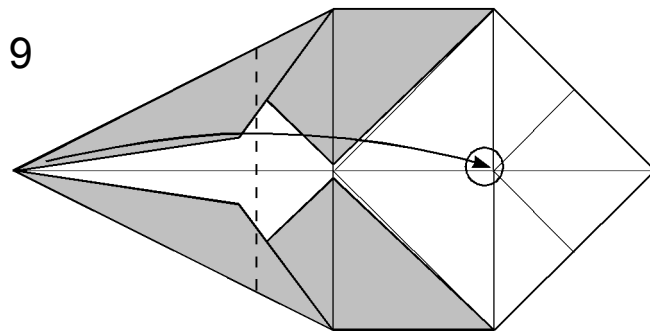

9. Fold the tip of the tail across to the left as shown. Picture 10 shows what the result should look like.

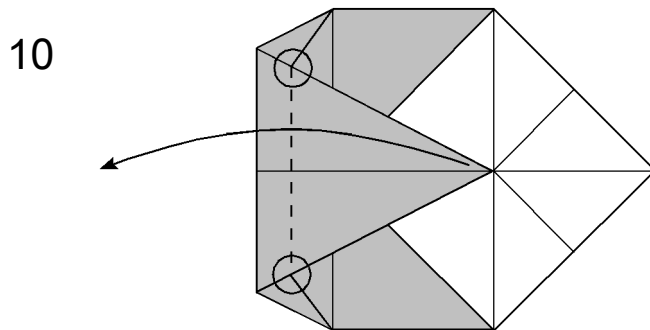

10. Fold the tip of the tail back out to the right. The circles show how the crease is located. Picture 11 shows what the result should look like.

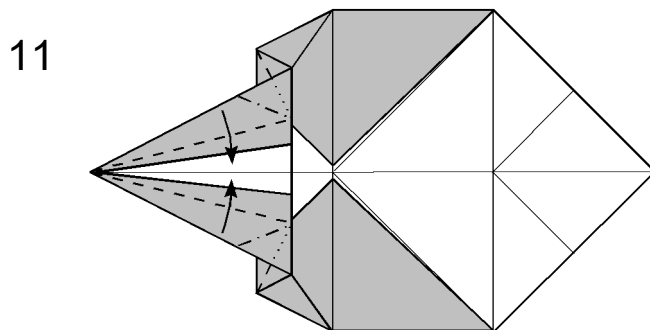

11. Narrow the tail by folding both edges to the horizontal crease in turn. You will find that in order to flatten the paper you need to make two more tiny folds at the base of the tail. Picture 12 shows how these folds should be arranged.

12

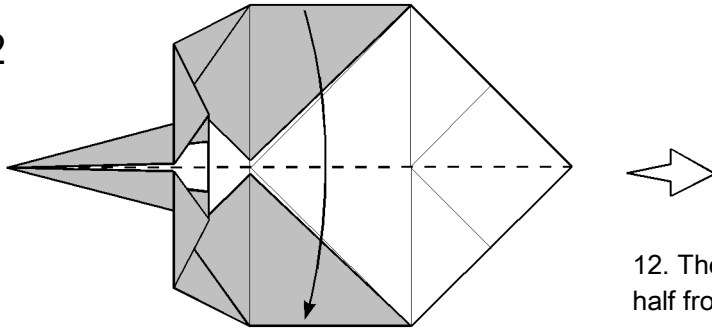

12. The tail is finished. Fold in half from top to bottom.

13

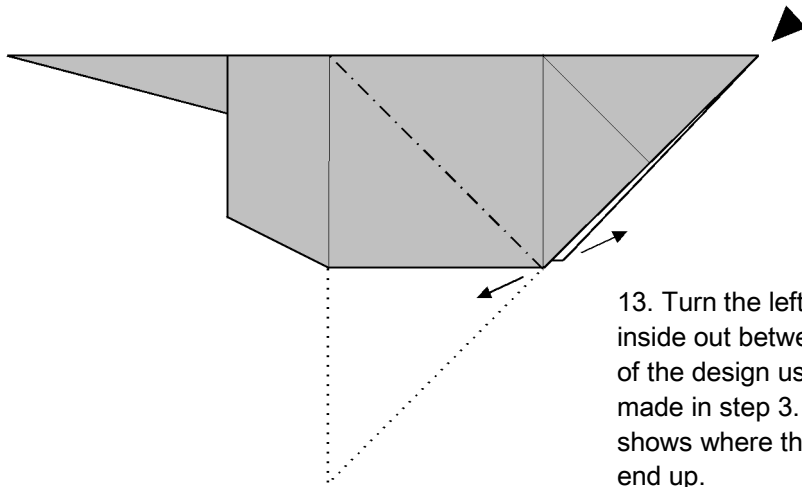

13. Turn the left hand point inside out between the layers of the design using the crease made in step 3. The dotted line shows where the point should end up.

14

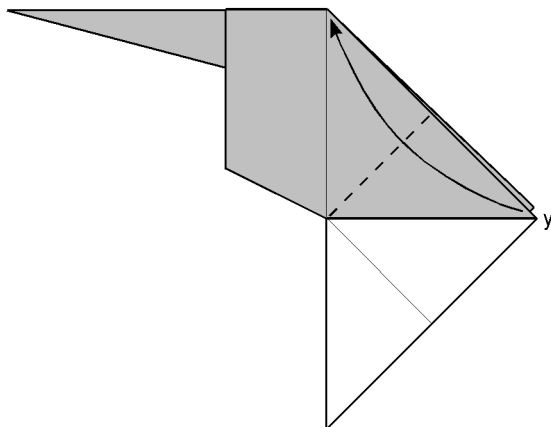

14. This fold is only made in the top layers of the paper. As you flatten the paper after making the fold point z will end up at point x. Crease firmly.

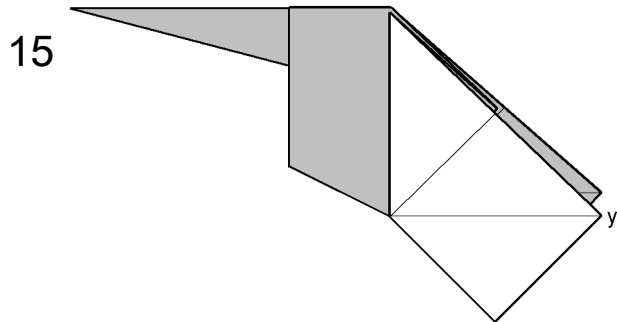

15. Turn over sideways.

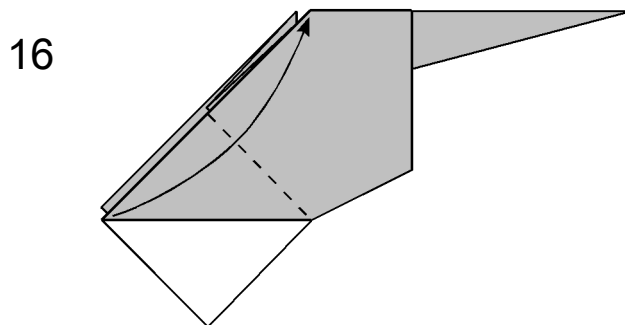

16. Repeat step 14 on this side of the design. Picture 17 shows what the result should look like.

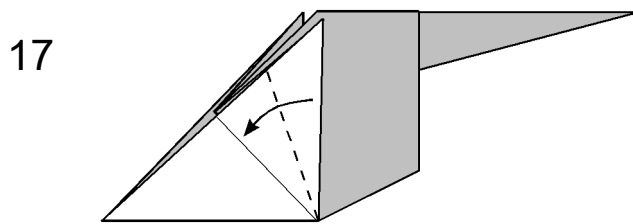

17. Form the first ear by folding the right hand edge of the triangular flap across to lie on top of the diagonal crease. Crease firmly.

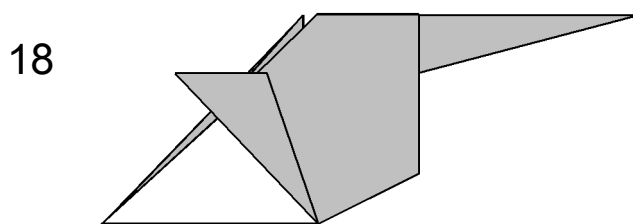

18. Turn over sideways.

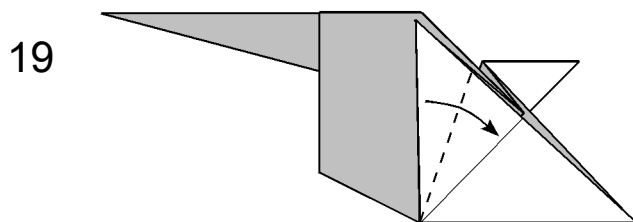

19. Repeat step 17 on this side of the paper.

20

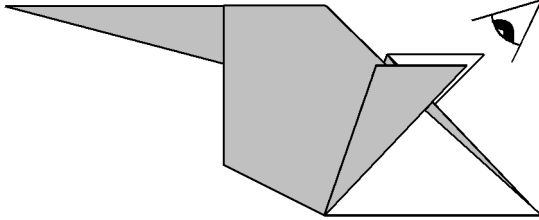

20. The next picture shows the view from above the ears.

21

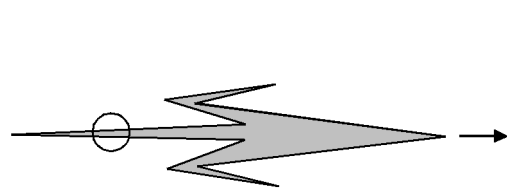

21. Hold the top of the body in the place marked with a circle and pull gently on the nose. The layers inside the ears will pull out.

22

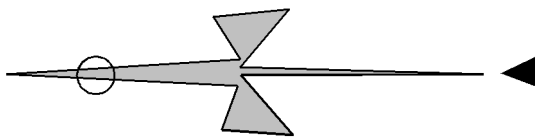

22. Now push the nose gently back into position making sure that the inner layers of the ears go in between the layers of the body.

23

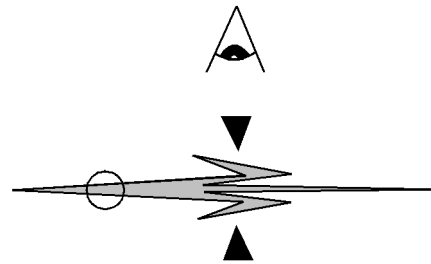

23. This is the result. Gently squash flat. The tension in the creases will hold the two sides of the head together.

24

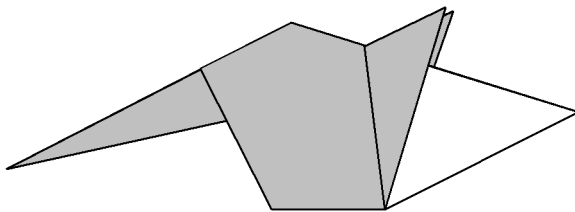

23. Mouse is finished.

Copyright David Mitchell 2015
www.origamiheaven.com