

# Magazine Cover Box with Strengtheners / Magazine Cover Box Cuboid

Magazine Cover Box of unknown origin. Strengtheners and Magazine Cover Box Cuboid designed by David Mitchell

The Magazine Cover Box is probably the simplest and quickest of all origami boxes to make. It can be made from A4 or US Letter size paper, or, as the name suggests, from the cover or inside pages of a magazine.

As far as I know this design was first published in 1978 in Vol 13 issue 4 of the *Origamian*. The diagrams include the information that 'Emily Rosenthal learned this in her German childhood -

from whom she does not remember'. The original form of the box is the shorter, broader version. The longer, narrower box is an obvious variation.

In 2005, while I was preparing my book 'Complete Origami' for publication, I played with these boxes to see whether, and if so how, the design could be enhanced or varied. I found that it was possible to add simple strengtheners to the boxes to make them more practical to use and also that it was possible to combine four of the shorter, broader version of the design to create a modular cuboid, that might be used, perhaps, as a simple gift container. The first idea made it into the book, the second did not.

When not made from a magazine cover, the Magazine Cover Box is usually made from paper that is the same colour both sides.

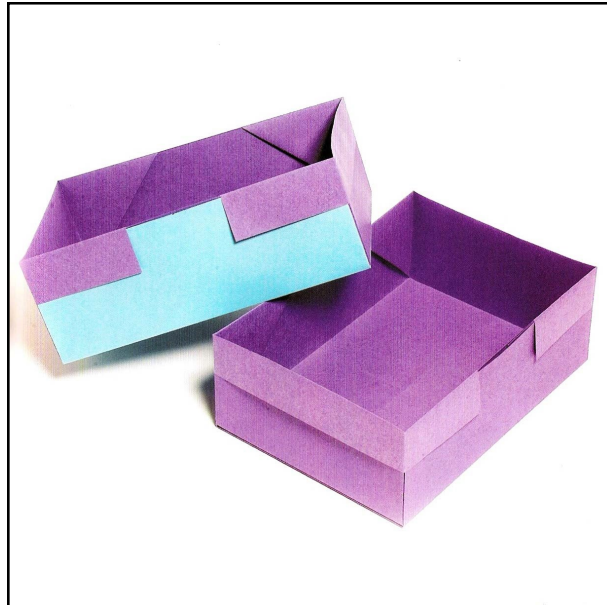

## Making the shorter, broader version

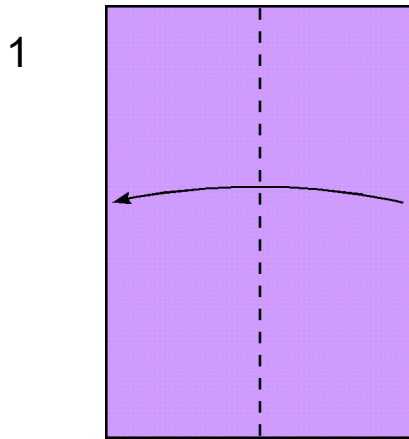

1. Fold in half sideways.

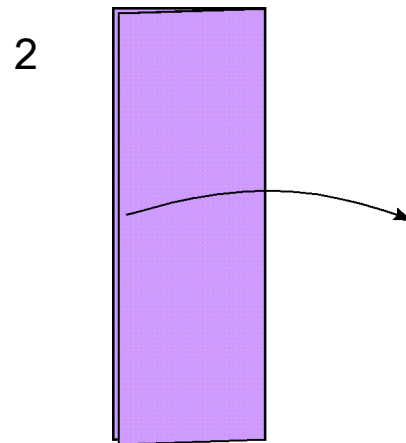

2. Unfold.

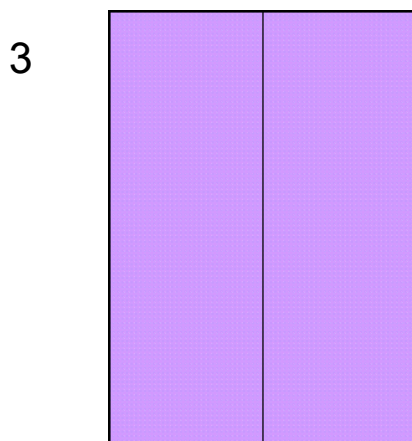

3. Turn over sideways.

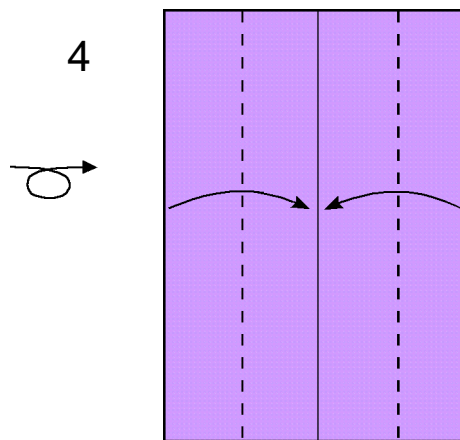

4. Fold both outside edges onto the upright centre crease.

5

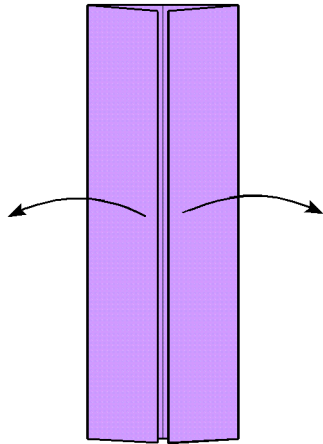

5. Unfold.

6

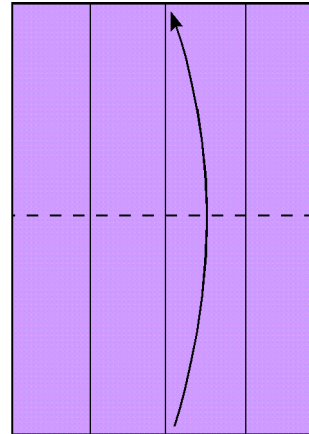

6. Fold in half upwards.

7

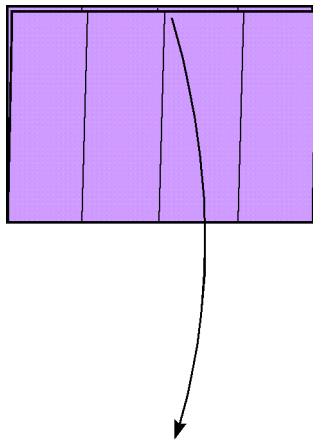

7. Unfold.

8

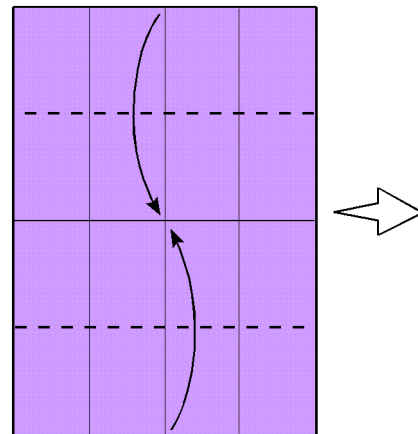

8. Fold both the top and bottom edges onto the horizontal centre crease. The next picture has been drawn to a larger scale.

9

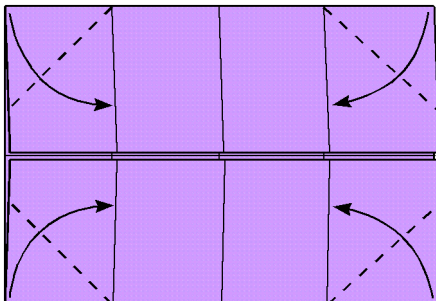

9. Fold all four corners inwards using the vertical creases made in step 4 as a guide to help you locate the folds.

10

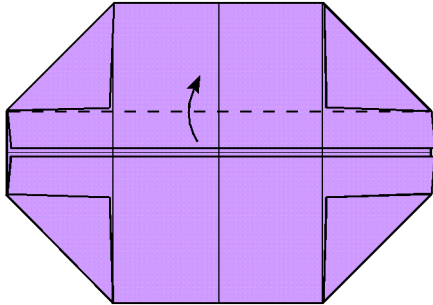

10. There are two loose flaps in the centre of the design. Fold the upper flap upwards as far as it will go to lock the triangular flaps created in step 9 in place.

11

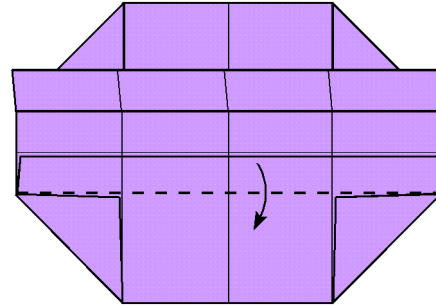

11. This is the result. Repeat step 10 on the lower loose edge.

12

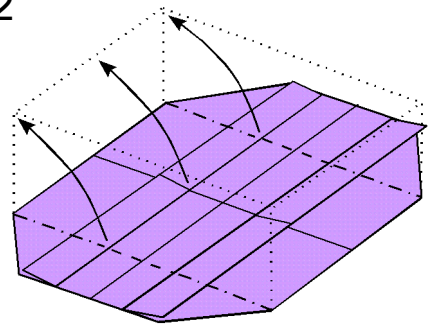

12. Lift one of the shorter sides of the box into place in the way shown here. As you do this the rest of the box will begin to take shape. Rework the corner creases to establish this shape. The dotted lines show where the sides of the box should form.

13

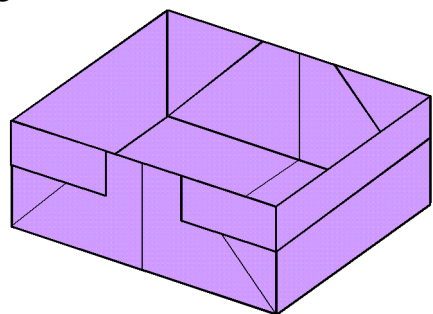

13. The basic Magazine Box is finished. This box can be used to hold paper clips, sweets, spare coins ... in fact almost anything small and loose you need to organise.

## Adding strengtheners

14

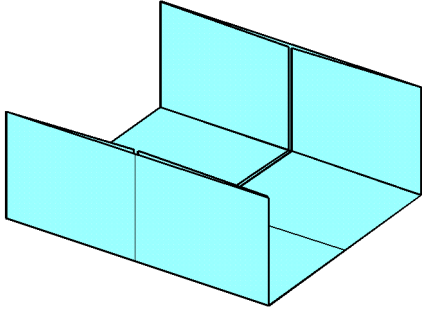

14. In its basic form the sides of the Magazine box are quite weak. You can make a strengthening piece by folding another rectangle of the same size to step 8 and then lifting the front flaps up so that it looks like this.

15

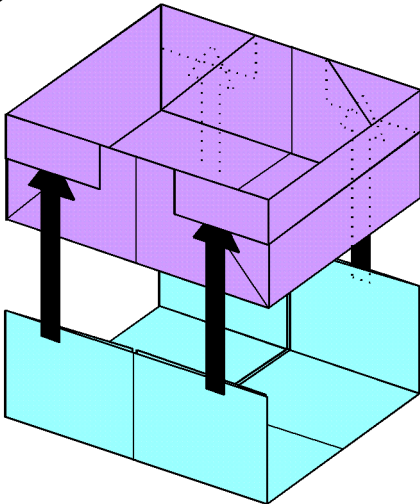

15. Tuck the edges of the strengthening piece into the pockets on the longer sides of the box as shown.

16

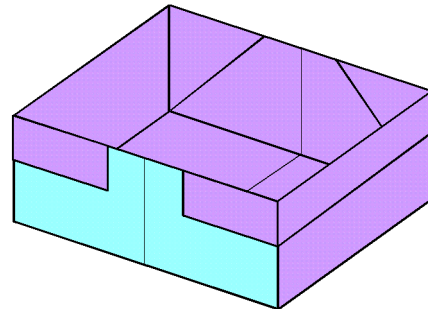

16. The Magazine Cover Box with Strengtheners is finished.

## Making the Magazine Cover Box Cuboid

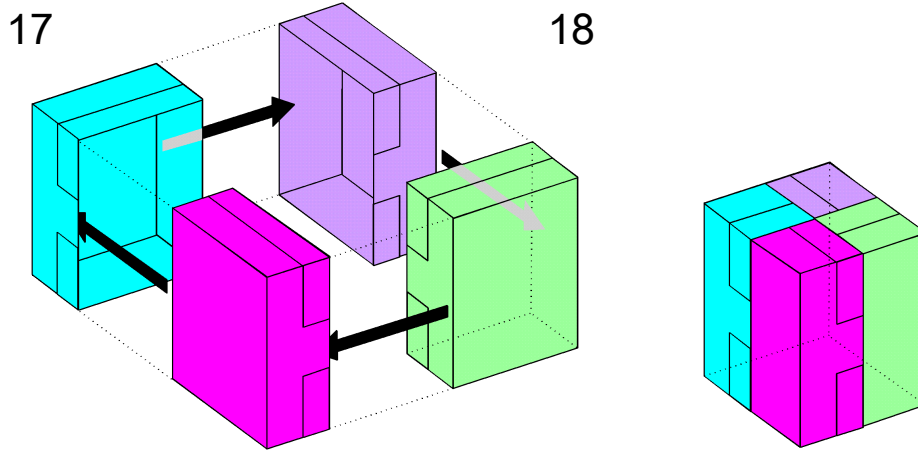

17. Make four of the shorter, broader version of the Magazine Cover Box and put them together as shown.

18. The finished Magazine Cover Box Cuboid will look like this.

## Making the longer, narrower version

You can make a longer, narrower version of the Magazine Cover Box by first following steps 1 to 8 of the shorter, broader box then steps 17 to 26 below. Once you have made followed instruction 8 open the paper out completely so that it looks like picture 17.

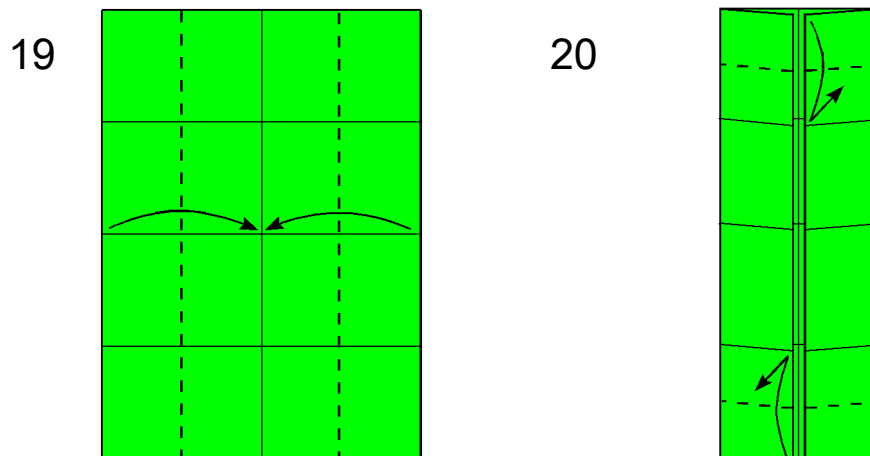

19. Fold both outside edges inwards using the existing creases.

20. Fold the top and bottom edges inwards using the existing quarter way creases as guides.

21

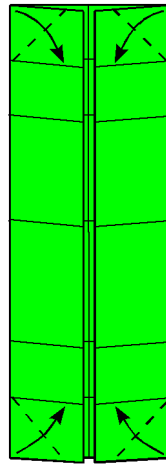

21. Fold all four corners inwards like this using the creases you made in step 18 as guides to help you locate the folds.

22

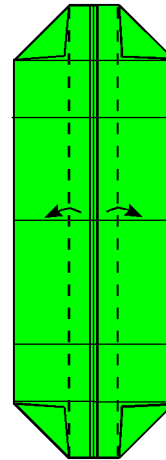

22. There are two loose flaps in the centre of the design. Fold them both outwards as far as they will go to lock the triangular flaps created in step 19 in place.

23

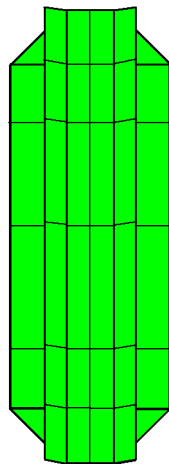

23. The result should look like this.

24

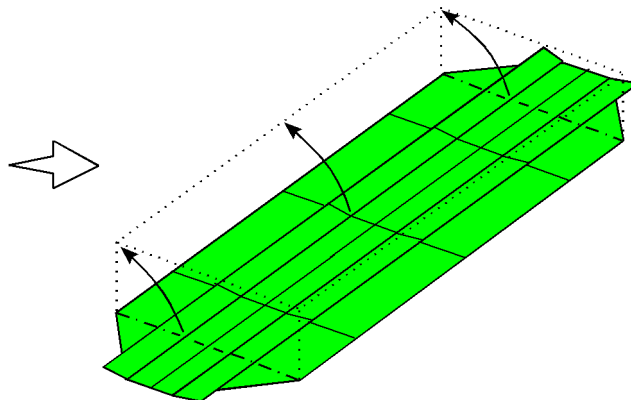

24. Lift one of the long sides of the box into place in the way shown here. As you do this the rest of the box will begin to take shape. Rework the corner creases to establish this shape. The dotted lines show where the sides of the box should form.

25

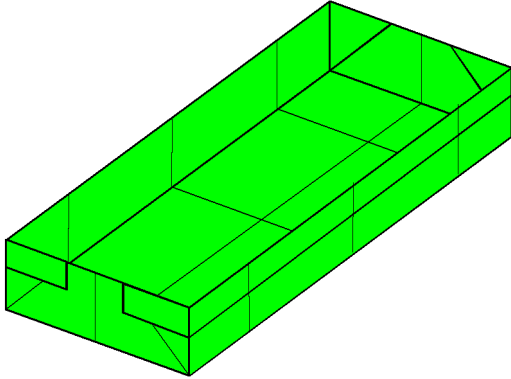

25. The basic longer, narrower version of the Magazine Cover Box is finished.

### Adding strengtheners

26

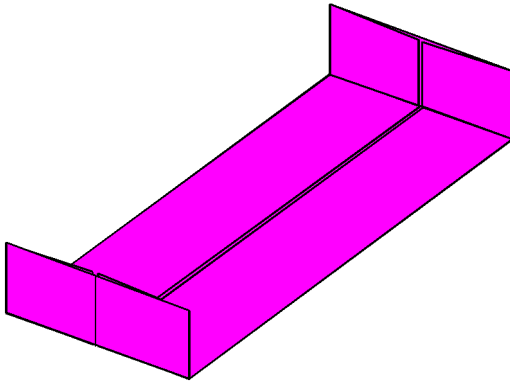

26. In its basic form the sides of this version of the Magazine box are quite weak. You can make a strengthening piece by folding another rectangle of the same size to step 18 and then lifting the front flaps up so that it looks like this.

27

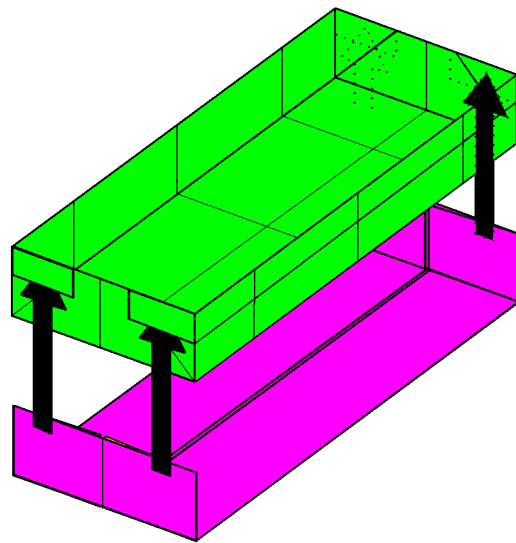

27. Tuck the edges of the strengthening piece into the pockets on the shorter sides of the box as shown.



28

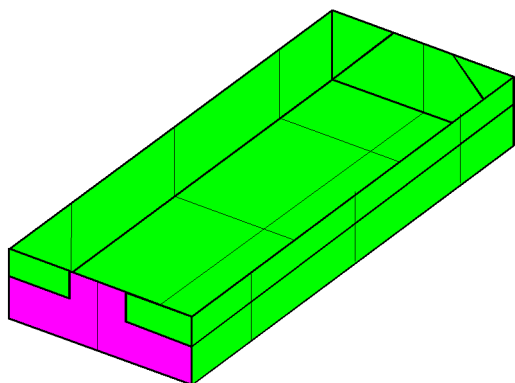

29. The longer, narrower version of the Magazine Cover Box with Strengtheners is finished.

Copyright David Mitchell 2019  
[www.origamiheaven.com](http://www.origamiheaven.com)