

# Jumbo

Designed by David Mitchell

Jumbo is a simple front-on image of an elephant. A minimalist version of Jumbo can be achieved using just five active folds, but his appearance is vastly improved if additional shaping folds are added. As a designer I am particularly fond of the move in step 8 in which the back and front of the design are locked together.

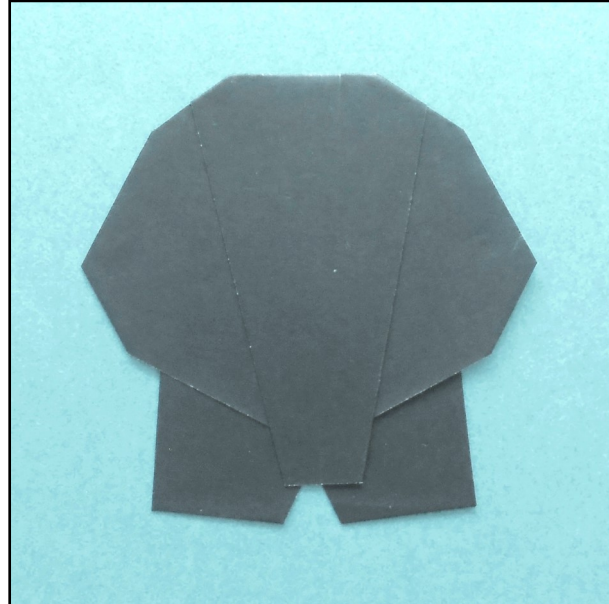

Jumbo was designed in 1993.

Jumbo is folded from a single square of paper. The whole of the visible surface of Jumbo comes from the same surface of the paper so that you can fold him from either irogami or homogeneous paper. If you are using irogami begin with your paper arranged white side up.

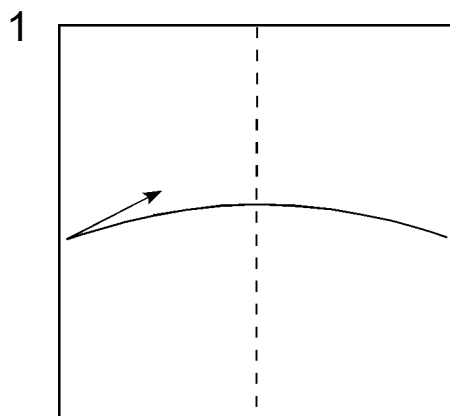

1. Fold in half sideways, then unfold.

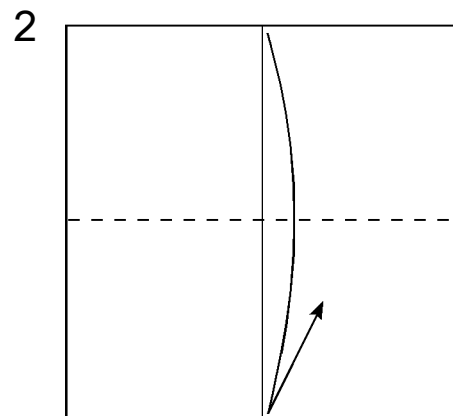

2. Fold in half downwards, then unfold.

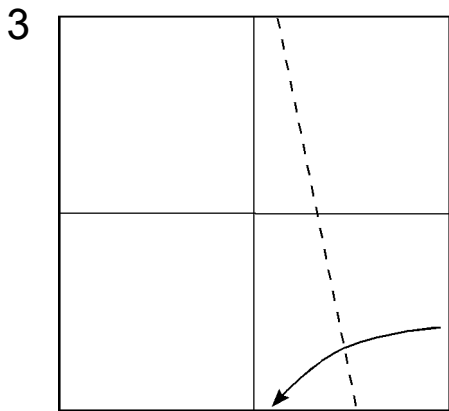

3. Look at diagram 4 to see how to make this fold. It begins close to the vertical centre crease along the top edge. When folded over the right hand edge ends up just short of the vertical centre crease along the bottom edge.

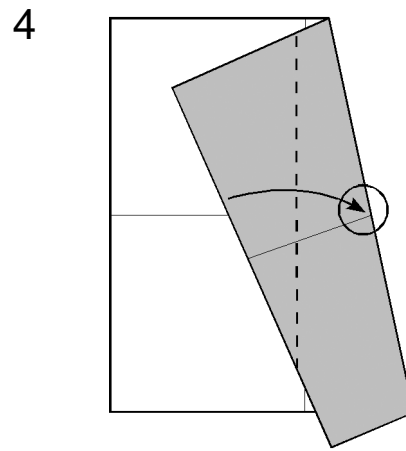

4. Fold the original right hand edge of the paper back on itself again. Once the fold is flattened down this edge must end up passing through the point marked with a circle, where the horizontal centre crease bisects the right hand edge.

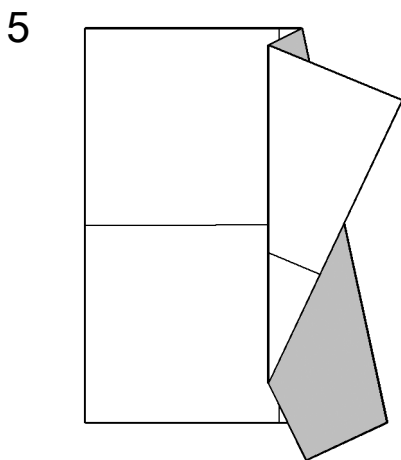

5. The sketch should now look like this. If necessary adjust the creases you have already made before moving on.

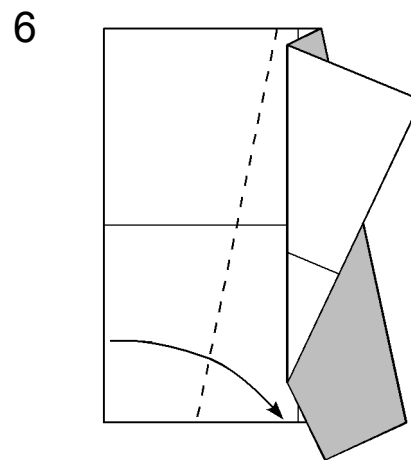

6. Repeat fold 3 on the left hand half of the paper.

7

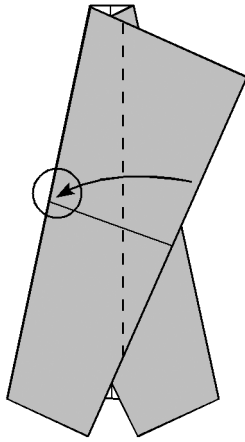

7. Repeat fold 4 on the left hand half of the paper.

8

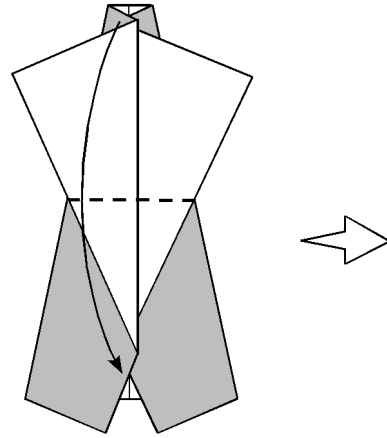

8. Fold in half using the horizontal centre crease made in step 2. As you do this the front and back halves of the model can be locked together by interweaving the internal folds.

9

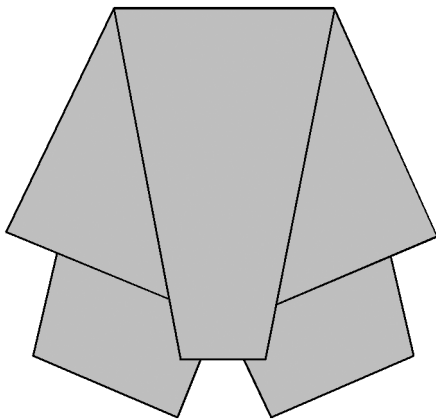

9. This minimalist version of Jumbo is complete in all his essentials but his appearance can be made much more lifelike by adding some final shaping folds. Begin to do this by turning him over sideways.

10

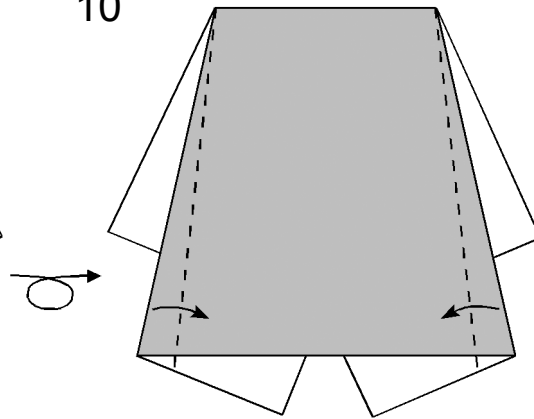

10. Fold both sides of the front layers inwards.

11

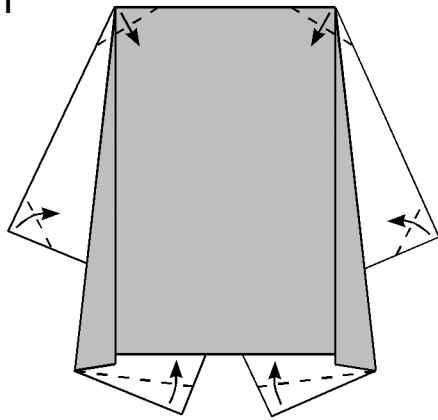

12

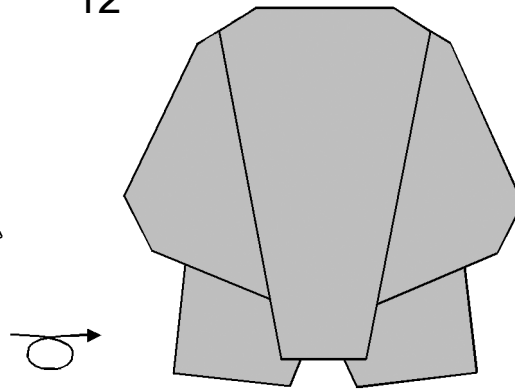

11. Make six small shaping folds like this, then turn over sideways again.

12. Jumbo looks much more realistic now.

Copyright David Mitchell 2018  
[www.origamiheaven.com](http://www.origamiheaven.com)