

Hound

Designed by David Mitchell

Hound is a very basic design which I created for my book *Origami Animals* in 2005.

Other designers have come up with essentially similar paperfolds.

Hound is folded from a single square of paper. If you are using irogami begin with your paper arranged white side up.

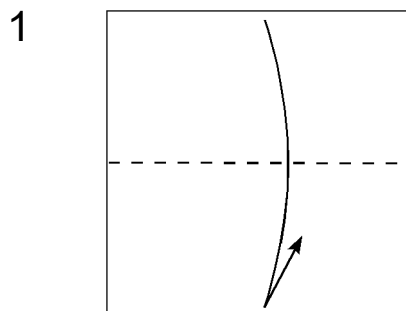
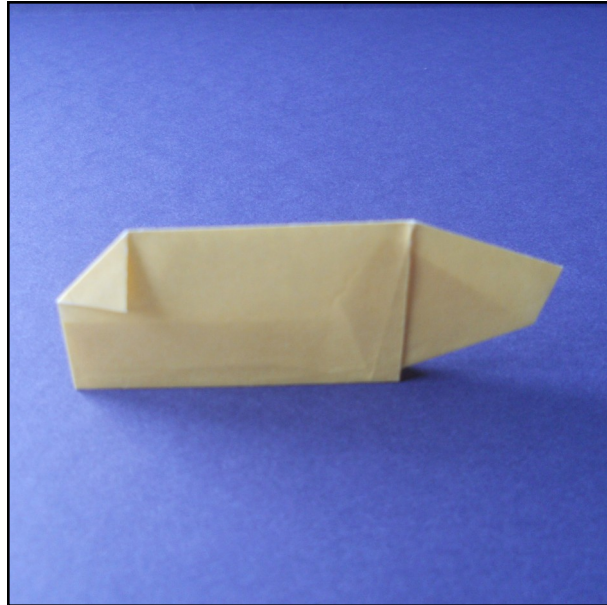

1. Fold in half from top to bottom, crease firmly, then unfold.

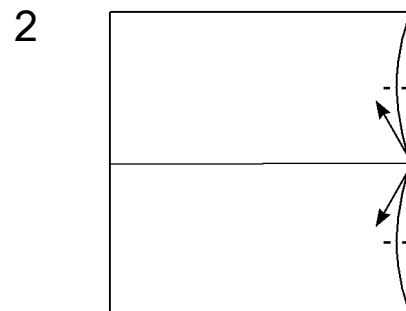

2. Fold both right hand corners to the horizontal crease in turn, then unfold. Try to keep your creases as short and neat as possible.

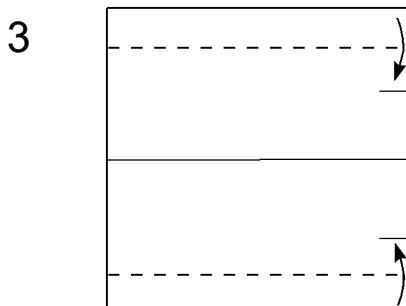

3. Fold the top and bottom edges inwards using the tiny creases made in step 2 as your location points.

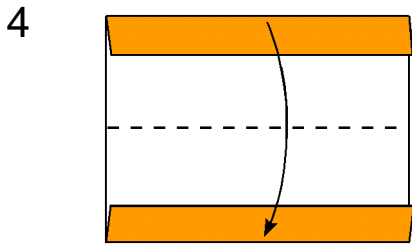

4. Fold in half from top to bottom.

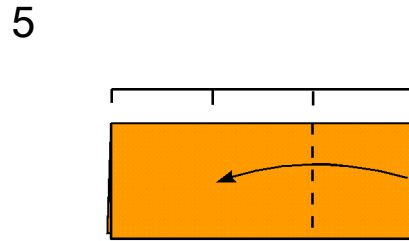

5. Fold approximately one third of the paper across to the right. make this fold softly at first and only crease it firmly when you are sure you have got the crease positioned correctly. Picture 6 shows what the result should look like.

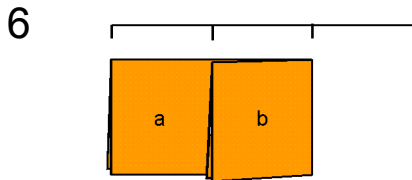

6. When the crease is in the correct position the two rectangles a and b should be the same size. Nearly the same size is good enough. Crease firmly.

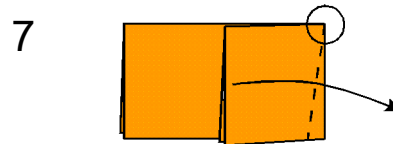

7. Fold the top flap back out to the right in the way shown here. Note that the crease passes through the top right hand corner and is made at a very shallow angle. Picture 8 shows what the result should look like.

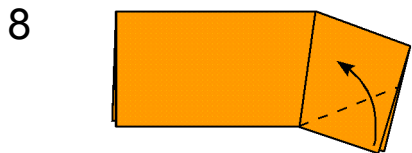

8. Fold both layers of the front flap upwards as shown. Make sure the crease begins where the bottom edge of the design changes angle. One way of checking if you have got your angles right is to lay your model on top of the diagrams!

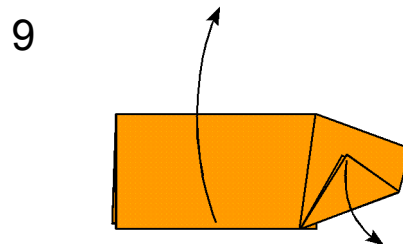

9. Unfold completely.

10

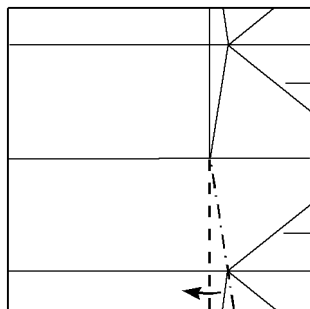

10. Make this fold using the lines of the existing creases. The right hand crease will need to be extended downwards slightly. The top half of the paper will not lie flat once this fold has been made.

11

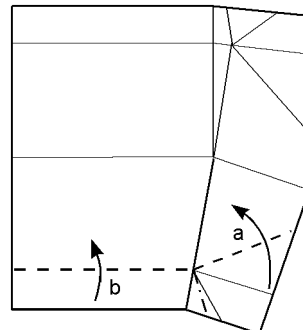

11. Make fold a then fold b using the existing creases. Only flatten the folds once fold b is made. A tiny new crease will form in between the other layers of paper as you do this. Picture 12 shows what the result should look like.

12

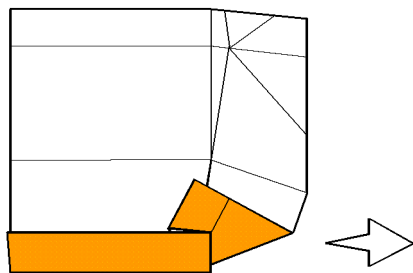

12. Repeat steps 10 and 11 on the top half of the paper. You will find this slightly more difficult because the direction of the creases will need to be reversed in order to make the folds. The design will not lie flat until step 13 is completed. The next picture has been drawn to a larger scale.

13

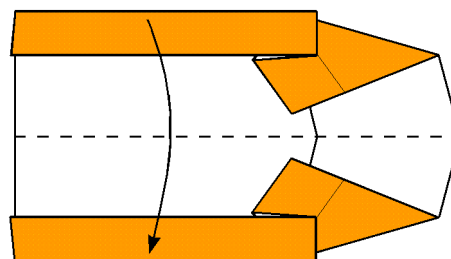

13. Fold in half to flatten.

14

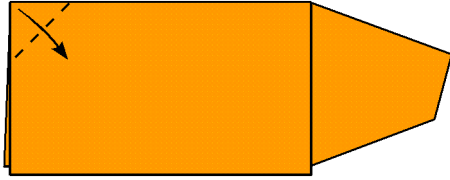

14. Make this fold to create a simple tail.

15

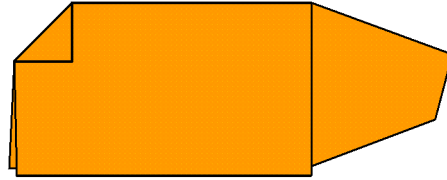

15. Hound is finished.

Copyright David Mitchell 2016
www.origamiheaven.com