

Delta Frame

Designed by David Mitchell

Delta Frame is a very simple design for a display frame can easily be made from a sheet of A4 or US letter sized paper that adapts itself to many different sizes of photograph or postcards.

I designed Delta Frame in 1996.

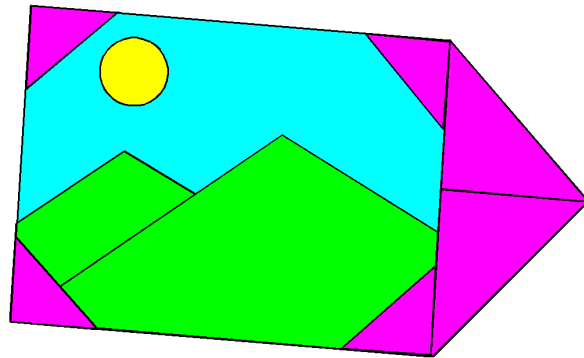

You will need a single sheet of paper for each frame. The paper needs to be a little wider than the photograph or postcard you wish to display.

1

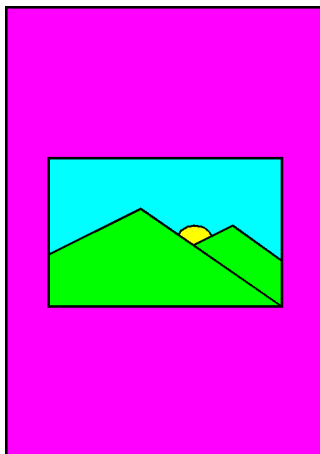

1. Place the photo you wish to frame in the centre of the paper.

2

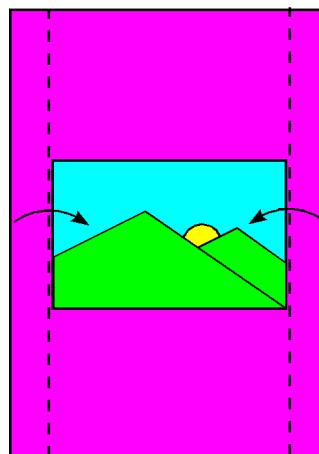

2. Fold both edges in around the photo. Try to ensure both creases are made parallel to the long edges of the paper.

3

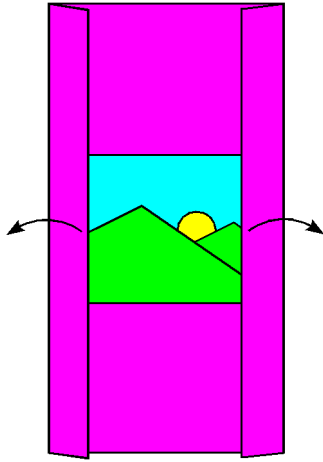

3. Undo the folds made in step 2.

4

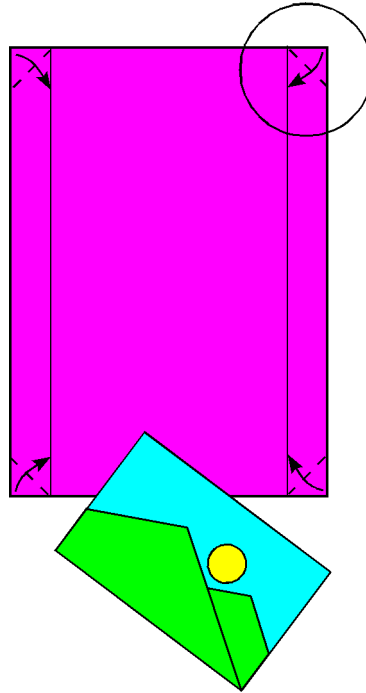

4. Remove the photograph and fold all four corners inwards in the way shown in steps 5 and 6 which are on a larger scale.

5

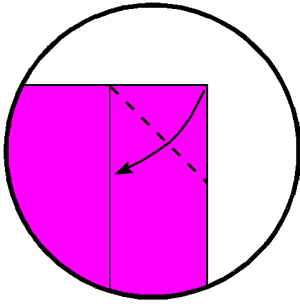

5. Fold the top edge of the double layer area onto the upright edge of the front layer. Repeat on all four corners.

6

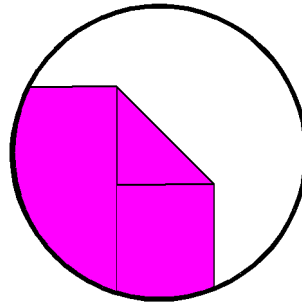

6. The result should look like this.

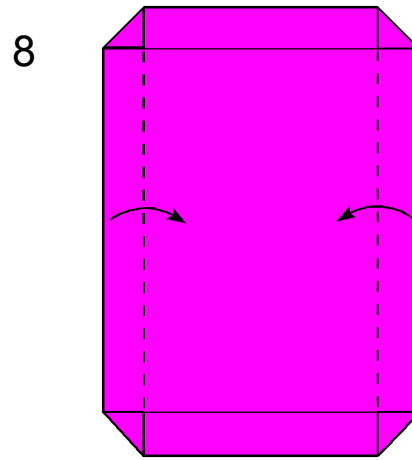
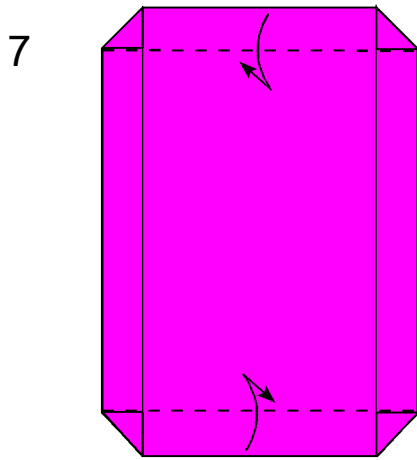

7. Fold the top and bottom edges inwards using the small top or bottom of the tiny triangular flaps at each corner to locate the folds, then unfold.

8. Remake the folds made in step 2.

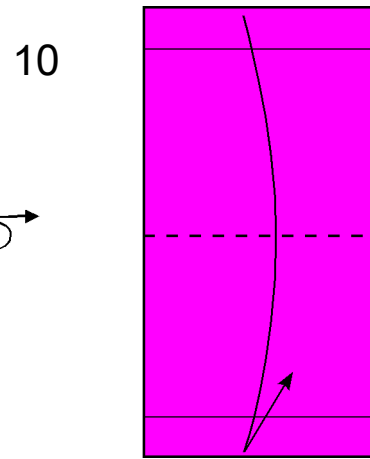
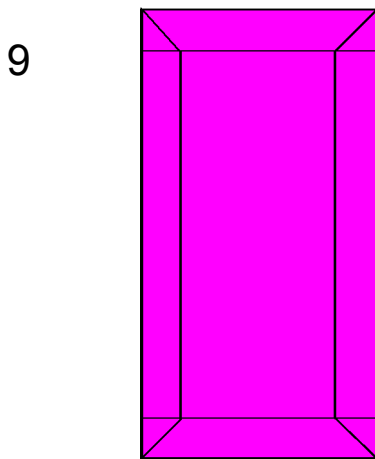

9. Turn over sideways.

10. Fold in half downwards, then unfold.

11

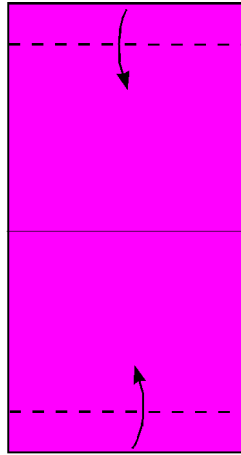

11. Fold the top and bottom edges inwards using the existing creases.

12

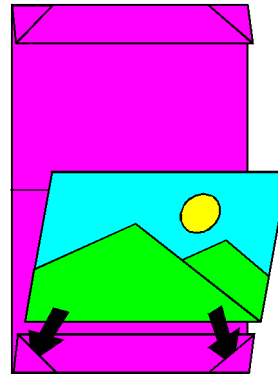

12. Slide the bottom corners of the photograph or postcard into the pockets at the bottom.

13

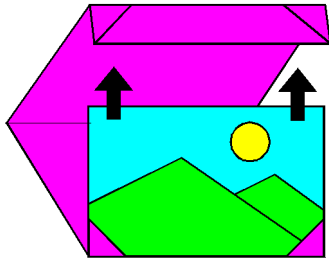

13. Slide the top corners into the top pockets in a similar way,

14

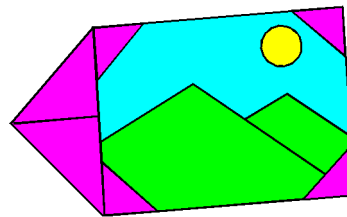

14. The Delta Frame is finished.

Copyright David Mitchell 2017
www.origamiheaven.com